

# Affordable Care

NorrDia  
HOLLOW FIBER HEMODIALYZER  
(High-Flux)



Affordable Care



# Affordable Care

Based on our teams' years of experience within the renal industry, NorrDia truly understands the evolving needs in modern dialysis care.

We recognise the changing demands of patients, healthcare professionals, as well as of healthcare globally. Our mission is simple: "Help professionals improve quality of care".

This mission is the foundation of NorrDia and drives everything we do.

Our dialysers can be used in HF, HD or HDF modalities. Manufactured in state-of-the-art facilities equipped with the latest technology, our NorrDia dialysers will consistently satisfy the requirements of patients, healthcare professionals and care providers.

By balancing performance, affordability, and environmental responsibility, NorrDia H dialyser series provides a smart choice in modern dialysis care.

## We call this Affordable Care

- CLINICAL PERFORMANCE
- OPERATIONAL SIMPLICITY
- ECONOMICAL CHOICE



# Clinical Performance

## High Permeability for Effective Treatment

NorrDia H dialyser series is designed for high permeability therapy, removing small and large uremic toxins to support effective haemodialysis. With high clearance rates, they enable the prescribed removal targets to be met within standard treatment times – critical for delivering high-quality dialysis care.

By enabling the effective elimination of uremic toxins and excess fluid, NorrDia H dialyser series helps achieve intended post-dialysis levels efficiently.

Performance data (see graphic on page 6) shows that NorrDia H dialyser series matches the removal rates of dialysers from leading ICHD brands, setting new benchmarks in dialysis treatment.

## High Permeability with Minimal Albumin Loss

The membrane of NorrDia H dialyser series has a well-defined and controlled pore size distribution, allowing removal of middle molecules while preserving essential proteins.

Maintaining blood albumin levels is important, as low albumin levels are associated with significantly higher mortality risks in dialysis patients<sup>1</sup>.

## Advanced Membrane Technology for Safe and Effective Treatment

NorrDia's membrane production allows controlled pore size distribution with a high overall porosity for optimal dialysis performance.

## BPA-Free for Enhanced Patient Safety

NorrDia H dialyser series prioritises patient safety with a BPA-free polypropylene housing, reducing exposure to bisphenol A (BPA) – a substance classified by the European Commission as toxic to reproduction (Category 1B) and an endocrine disruptor of very high concern (SVHC)<sup>2</sup>.

Without BPA by design, NorrDia H dialyser series minimises potential health risks associated with endocrine disruption, leading to a safer dialysis experience for both patients and the environment.

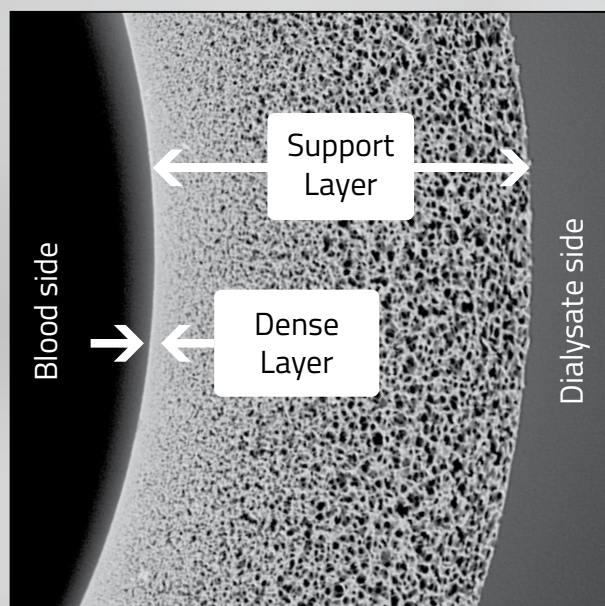

# Operational Simplicity

Optimised Flow Design to Reduce Clotting and Blood Loss

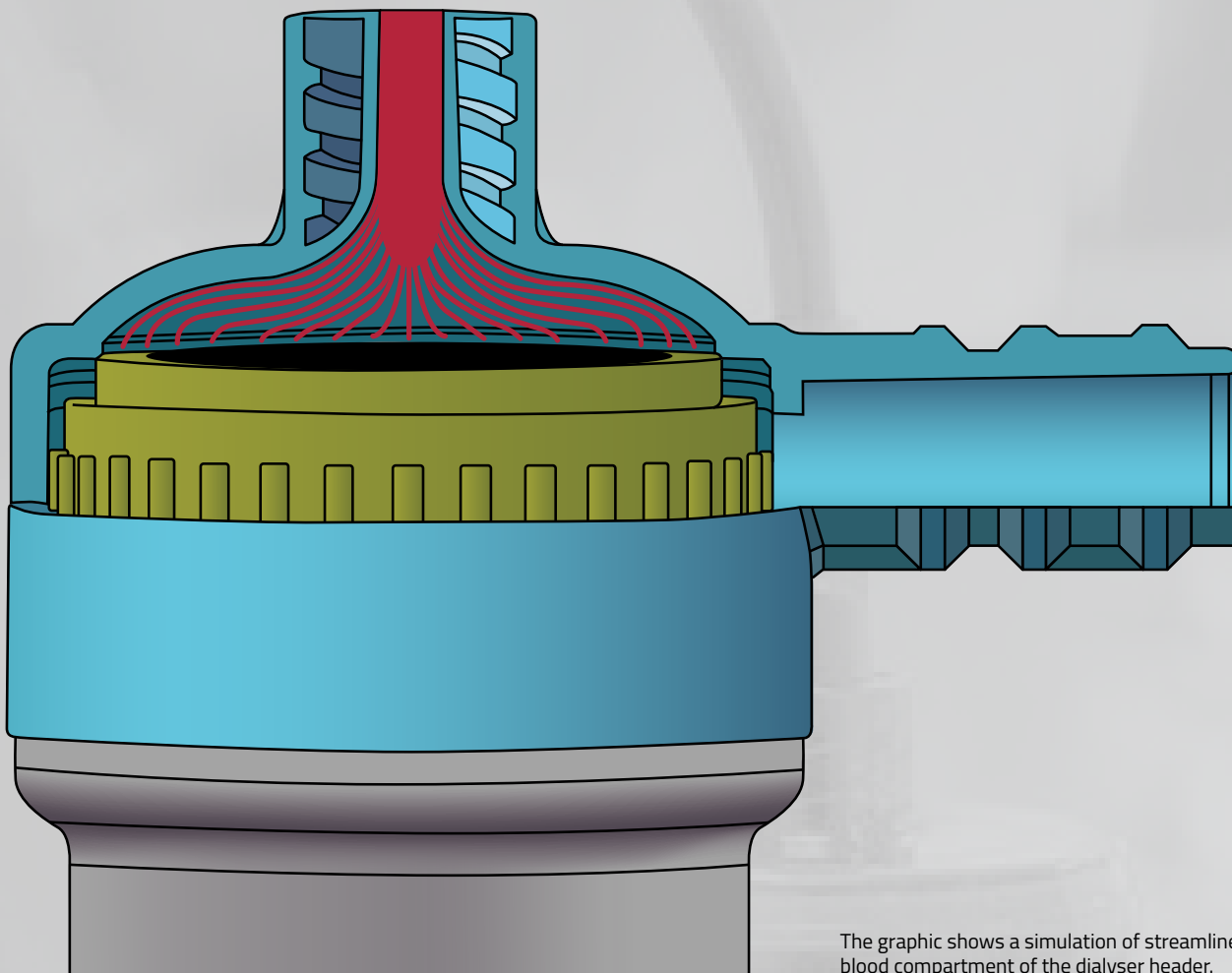

The graphic shows a simulation of streamline in the blood compartment of the dialyser header.

**Blood clot formation in haemodialysers is often linked to unfavourable flow conditions, and clotting may occur in low-velocity “dead zones” in the blood flow path<sup>3</sup>.**

Leveraging advanced hydrodynamic research, NorrDia H dialyser series features an optimised blood inlet design that facilitates a homogeneous blood distribution in the dialyser header.

By reducing dead zones, NorrDia H dialyser series may decrease the risk of clotting from areas with stagnant blood.

The optimised header geometry leads to better blood return at the end of treatment, supporting rinse-back and treatment efficiency.

## Efficient Priming for Time and Cost Savings

NorrDia H dialyser series features an optimised dialysate flow channel design, enabling top-down priming without the need for manual intervention.

This allows staff to use automatic priming functions without having to turn the dialyser, improving workflow efficiency and freeing up time for other tasks.

Efficient priming not only enhances usability but also reduces saline consumption, a factor in overall treatment costs.

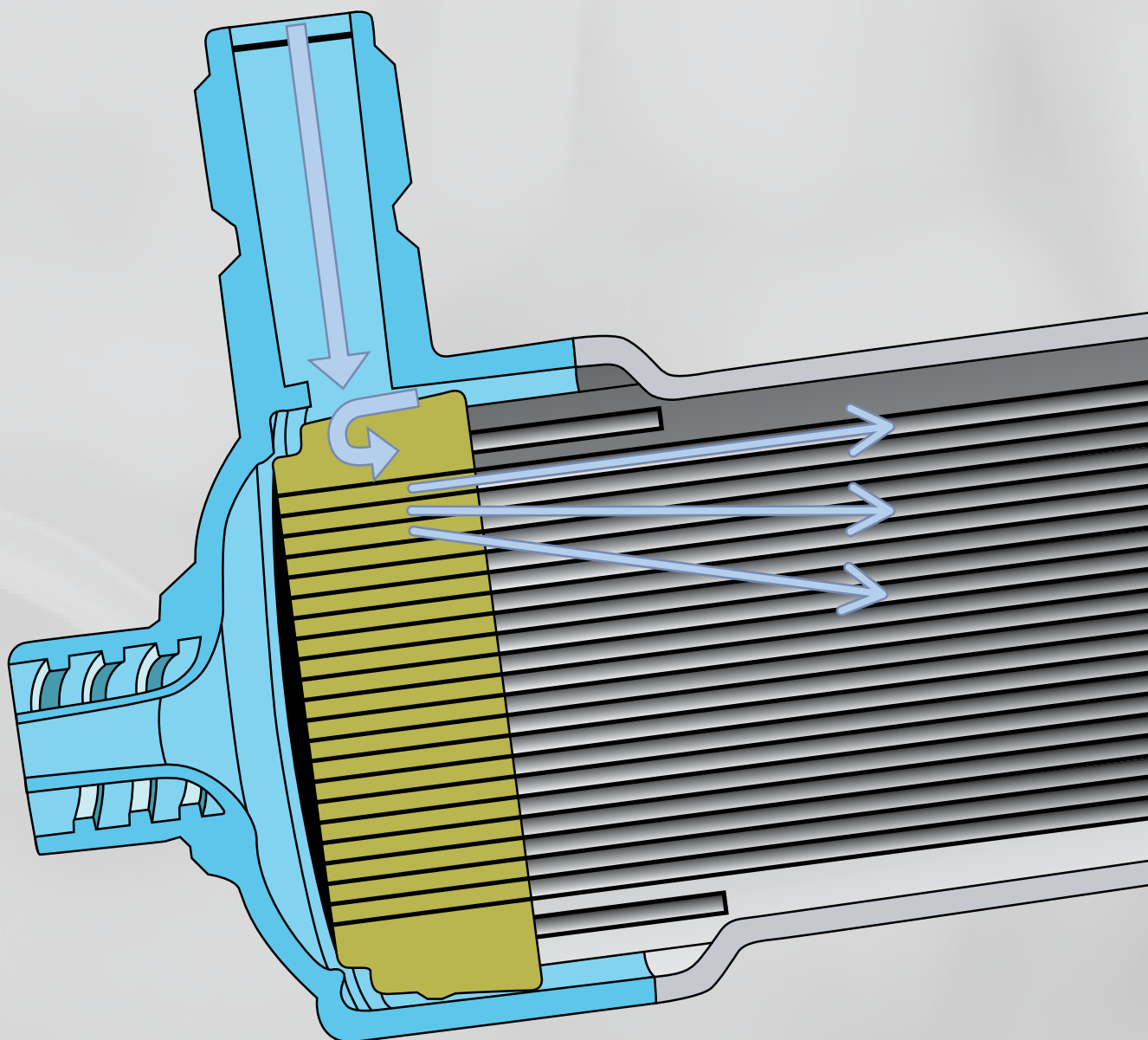
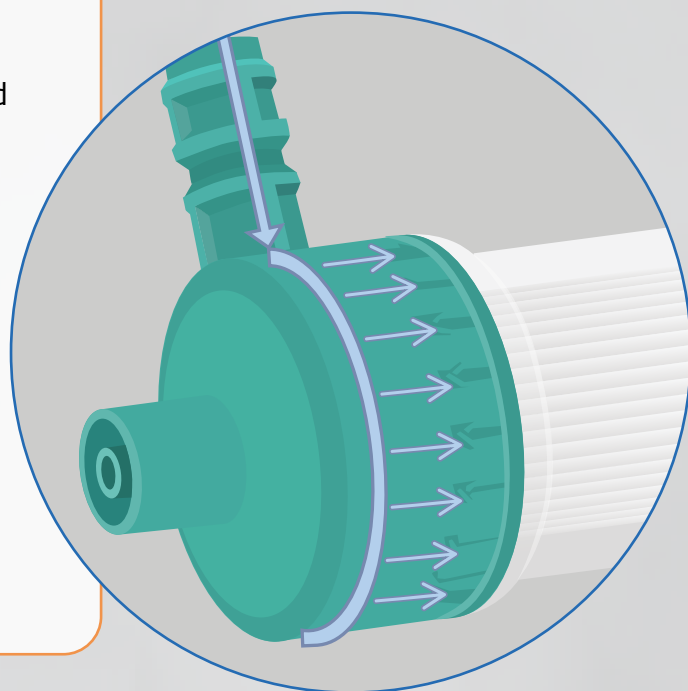

# Economical Choice

Manufactured with state-of-the-art production technology, NorrDia H dialyser series combines high-performance dialysis with cost efficiency. A lean supply chain ensures competitive pricing while meeting the evolving demands of renal care.

Designed for sustainability, NorrDia H dialyser series minimises plastic use and features a PVC-free polypropylene housing. Since clinical waste containing human blood typically requires incineration, PVC-free materials offer a cost-effective disposal advantage, as disposal of PVC-free plastic is often more economical than PVC-containing alternatives.

By balancing performance, affordability, and environmental responsibility, NorrDia H dialyser series provides a smart choice for modern dialysis care.

## Comparison with Leading Brands

The performance graphic shows that the NorrDia H dialyser series matches the standards set by other top-tier brands in the market.

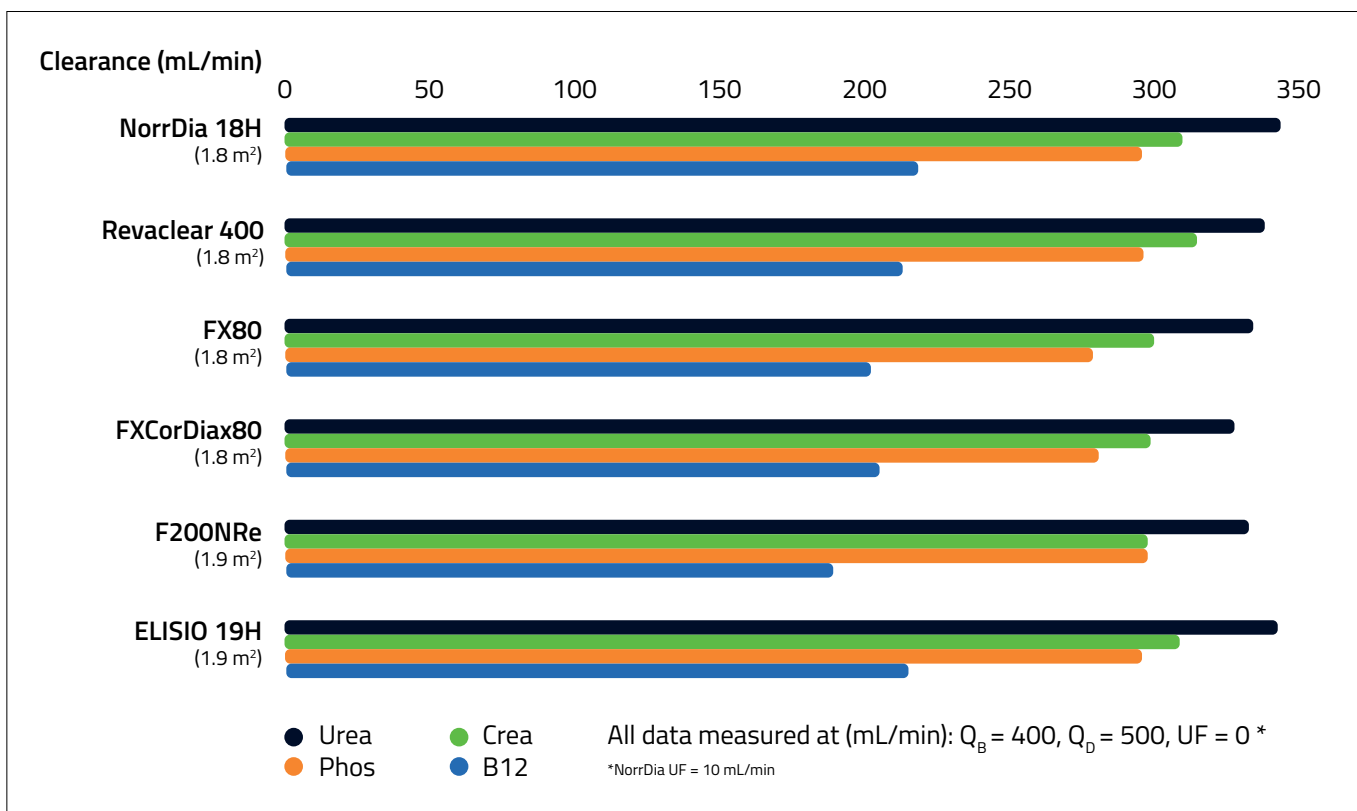

### Data Sources:

#### Baxter

Revaclear Datasheet Doc. No. GBU-RC38-200001 v1.0 – December 2020

#### FMC

FX classix: F00006437 MT-EN (1.0 BG-pppp 08.14)

FX CorDiax: F00002818 DE (V&B – Studiodruck 09.11)

F200NRe: F50010927 Rev 07/2023

#### Nipro

Elisio Dialyser - brochure Doc. No. Bro-Elisio - EN - 13.Dec.18

# Product specifications

## MATERIALS

Membrane	Polyethersulfone (PES) hollow fibre membrane
Potting	Polyurethane
Housing	Polypropylene
Gaskets	Silicone
Protection caps	Polyethylene
Sterilisation	Radiation sterilisation
Sterile barrier	PE-PA synthetic film

## SPECIFICATIONS

	NORRDIA- 14H	NORRDIA- 18H	NORRDIA- 20H	NORRDIA- 22H	NORRDIA- 24H
UF-Coefficient (mL/(h*mmHg))	53	68	75	83	90
KoA urea* (mL/min)	1190	1614	1832	1900	2269
Blood Compartment volume (mL)	78	101	110	121	134
Minimum recommended priming volume (mL)	500				
Maximum TMP (mmHg)	500				
Storage conditions	0-40°C (32°F-104°F)				
Units per box	24				
Unit net weight (g)	155	166	188	192	200

## MEMBRANE

	NORRDIA- 14H	NORRDIA- 18H	NORRDIA- 20H	NORRDIA- 22H	NORRDIA- 24H
Effective Membrane Area (m <sup>2</sup> )	1,4	1,8	2,0	2,2	2,4
Fibre inner diameter (µm)	200±20				
Fibre wall thickness (µm)	40±10				

## SIEVING COEFFICIENTS\*

β2-microglobulin (11,8 kDa)	0.9±0.1
Myoglobin (17 kDa)	0.5±0.1
Albumin (66,4 kDa)	≤0.008

## CLEARANCES IN VITRO (mL/min)

### HAEMODIALYSIS MODE (HD)

#### Q<sub>B</sub>/Q<sub>D</sub> (mL/min)

Urea (60 Da)	NORRDIA- 14H	NORRDIA- 18H	NORRDIA- 20H	NORRDIA- 22H	NORRDIA- 24H
200/500	195	199	200	200	200
300/500	275	288	292	292	297
400/500	318	344	350	352	365

#### Creatinine (113 Da)

200/500	193	196	198	199	200
300/500	258	270	274	278	283
400/500	290	310	320	330	338

#### Phosphate (142 Da)

200/500	181	191	194	196	196
300/500	236	255	262	268	274
400/500	268	296	310	318	326

#### Vitamin B12 (1.4 kDa)

200/500	138	159	165	169	175
300/500	168	195	203	211	223
400/500	186	218	225	233	245

Reference Document Version: ZOEY-TXQ-Norrdia-GT-IFU-01\_A01 2025.05.23

\*According to ISO 8637-1: 2017

- UF-Coefficient: measured with bovine blood, Hct 32%, Pct 60g/L, 37°C

- KoA urea: calculated at Q<sub>B</sub> = 300 mL/min, Q<sub>D</sub> = 500 mL/min, UF = 0 mL/min

- Clearances In Vitro: measured at UF = 10 mL/min

## References:

1- Kalantar-Zadeh K, Ficociello LH, Bazzanella J, Mullon C, Anger MS. Slipping Through the Pores: Hypoalbuminemia and Albumin Loss During Hemodialysis. *Int J Nephrol Renovasc Dis.* 2021 Jan 20;14:11-21.

2- Commission Regulation (EU) 2024/3190 of 19 December 2024 on the use of bisphenol A (BPA) and other bisphenols and bisphenol derivatives with harmonised classification for specific hazardous properties in certain materials and articles intended to come into contact with food, amending Regulation (EU) No 10/2011 and repealing Regulation (EU) 2018/213

3- Suranyi M, Chow JS. Review: anticoagulation for haemodialysis. *Nephrology (Carlton).* 2010 Jun;15(4):386-92.



### Suzhou ZOEY Medical Devices Co., Ltd.

2nd Floor, Building 18, Guanpu Road  
No.333, Guoxiang Street, Wuzhong  
Economic Development Zone, 215100  
Suzhou, China



### MedPath GmbH

Mies-van-der-Rohe-Strasse 8  
80807 Munich  
Germany



### NorrDia Belgium BV

Industriepark 6  
3300 Tienen  
Belgium

[www.norrdia.com](http://www.norrdia.com)